



The following is an extract of the feature article contained in *The Wildcat*, Volume 1, Number 1 originally published on August 2, 2010 by the AMPS Central South Carolina chapter of the Armor Modeling and Preservation Society.

“Scale Sized Slotted Screw Heads?! How’d he do that?”

Problem: How to make slotted screw heads (recessed, flush, or standing proud) on a model?

Solution: Make a jig and a fine saw blade to cut slots in the end of styrene rod of various diameters. The slotted rod can then be set into holes drilled on the model with the slotted end either recessed, flush, or standing proud of the model surface.

Tools and supplies needed:

1. Styrene stock – Rectangular and round rod. The dimensions on the rectangular stock are not too important. The stock just needs to be large enough to handle (i.e. sized to fit your minimum finger / hand grasping capacity). The diameter of the rod depends on the size of the screws you want to make. I’ve used .025 and .035 rod effectively. Note that Evergreen Styrene rod stock varies in diameter from the nominal size listed on the package. My .025 rod runs from about .024- to about .026+. My .035 rod runs from about .034- to about .036+.
2. Miniature drill bits and a pin vise. For .025 (nominal) diameter rod, numbers 73 through 70 will work. For .035 (nominal) diameter rod, numbers 66 through 64 will work.
3. X-acto knife (number 1 handle will be fine) and a new No. 11 blade.
4. A ruler (with fine gradations) for marking the centerline of the rectangular styrene stock. By the way, I use metric for all my work because the math is easy. A dial caliper makes laying out the center line very easy. (You can use it to measure and scribe in one step.)
5. Fine, 0000 steel wool. This is for buffing the screw holes on the model surface after they’ve been drilled. This buffing will slightly relieve the edges of the holes and allow your hard work to show after painting. (A set of micro hole-reamers - sometimes, incorrectly, called broaches - is useful, but not essential.)
6. A sanding block, Flex-i-File, fine sanding stick, etc. This will be used to put a flat end on the rod stock before you slot it.

7. Dremel Tool with a metal cut-off wheel. The cut-off wheels are the thin salmon-colored ceramic metal cutting disks.

Step 1.

Mark the centerline (CL - centerline) of the rectangular styrene stock. The purpose of this is to increase the accuracy of the work by providing a reference line. It's more important that the line be parallel to the sides of the stock than in the exact center of it. (You can use a dial caliper, compass or parallel cutter to scribe this line. By scribing twice, once along each side, you will make two lines parallel to each other with the exact center between them. This will compensate for any inaccuracy in measuring.)

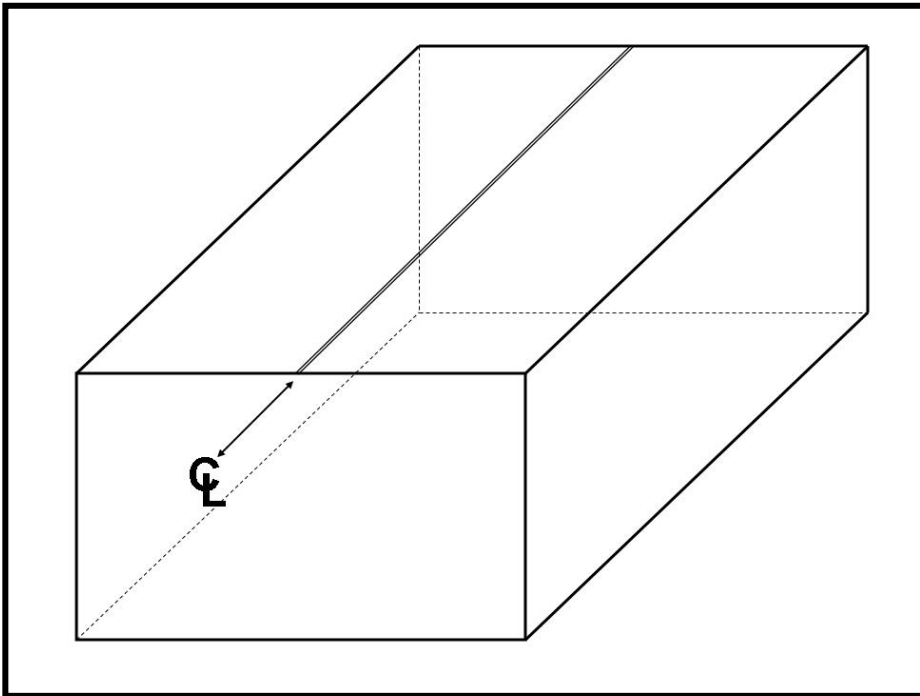

The rectangular stock will become the slotting jig, and while you're making it, you can drill it for several sizes of rod. The length of the jig depends on how many holes you're going to drill and how long a piece you need for comfortable work. Longer is better to start with. You can always cut it down to a shorter length later.

Step 2.

Drill holes for the size (D – diameter) rod you will use for the screws through the rectangular stock. Test fit the rod in the holes to make sure it will fit through without any excessive play. You may find (like I did) that for each size of rod, I needed to drill 3 or 4 slightly different sized holes. After I drilled the holes on my jig, I scribed the hole-sizes on the side of the jig for future reference.

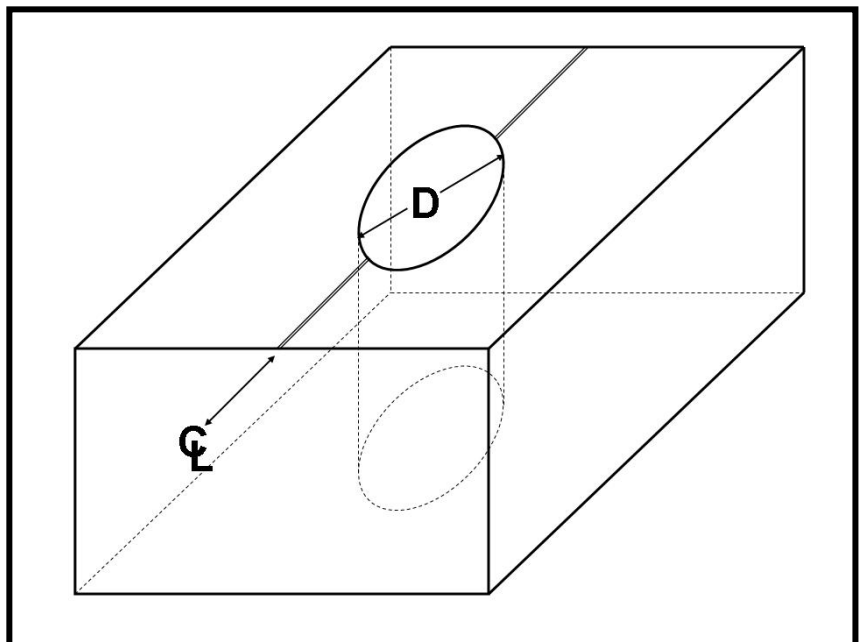

Step 3.

Make an “ultra-fine” saw blade from a number 11 blade. Chuck the blade in a handle and use your Dremel Tool to notch the edges of the blade, forming saw teeth along the blade. I spaced the notches about the thickness of the cut-off wheel apart. These notches don’t need to be very deep (about 1 mm or less). More teeth are better than fewer. Spacing should be as even as you can get, but it’s not critical and eyeballing it will be good enough.

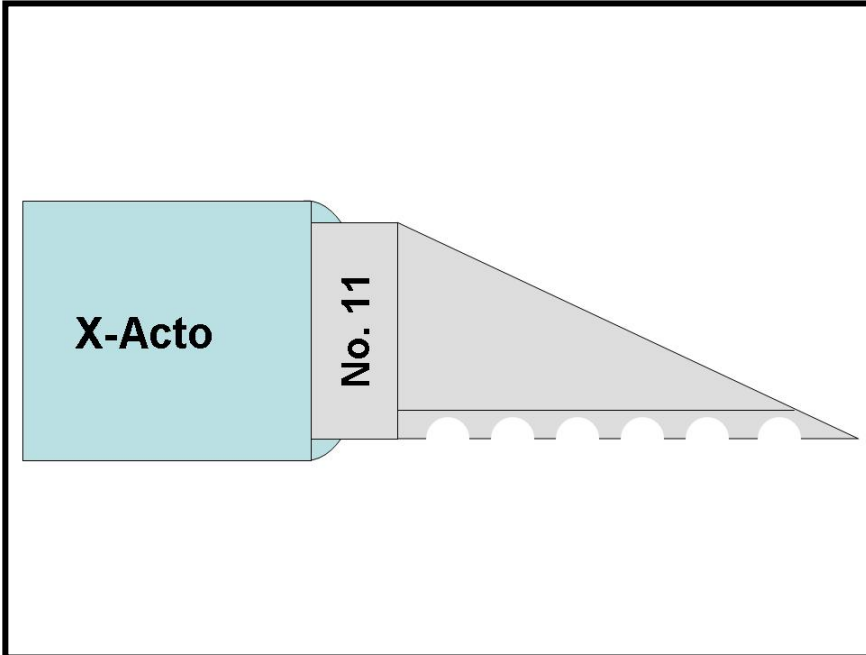

you can get, but it’s not critical and eyeballing it will be good enough.

I know of all of that was overly complicated to explain, so here’s a look at the actual jig and saw blade. You can see in the photo below that, despite the appearance of engineering perfection, it’s really more “field expedient.”

Note in the photo that there are holes marked 24, 25, and 26. These are for the minor differences in the diameter of

the Evergreen styrene rod, which has a nominal diameter (in this case) of .025 inches. I just use the hole-size that the rod fits best into so that it will not rock in the jig as I cut the slots. I don’t usually find that I need to drill different sized holes in the model since I relieve the outside edges to emphasize the added screw heads. (See “Additional Tips and Thoughts” and the examples below to see what I mean by “relieving” the edges of the holes to make the screws more visible.)

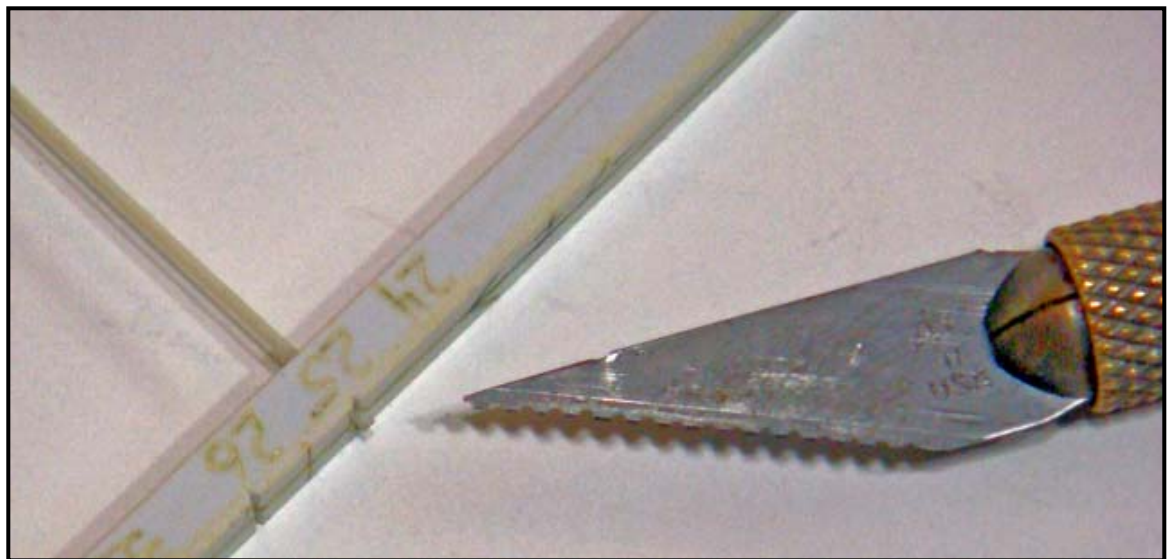

Step 4.

Using your new “ultra-fine” saw blade, cut a shallow slot across the center of each hole you drilled in

the rectangular stock. This slot will act as a guide for the saw as you cut the slots in the ends of the rod stock

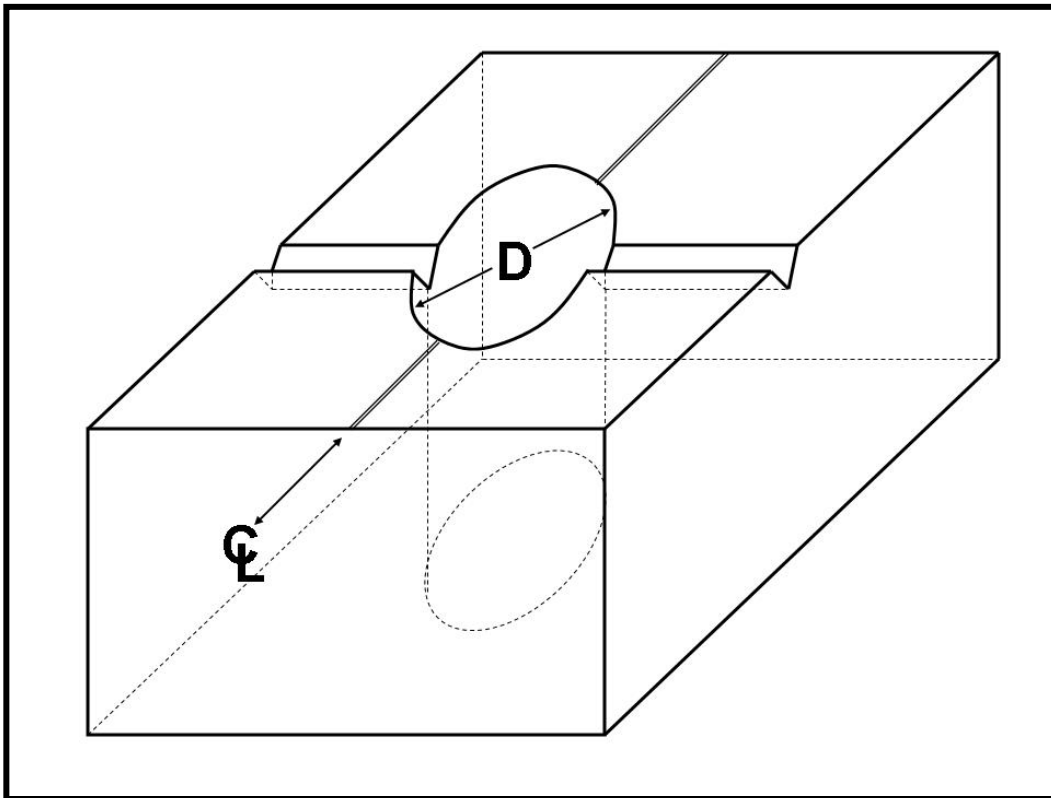

So, now that you have all these new, homemade tools...

How do you use the slotting jig?

You've obviously already done your homework (research), and you know where you want to put screw heads on your model (and whether they should be recessed, flush, or standing proud of the surface).

I usually make a copy of the appropriate plan view of the prototype that I'm building. Most often you can download something useful from the internet. If not, I make a photocopy (scan and print, actually) of plans in a reference book. I use these copies for notes as I peruse my other references, so that when I see details that I want to add to my model, I make notations and sketches on the photocopy instead of in my prized books. (Actually, many of my books are filled with pencil notes, too – oh, well...)

Step 1.

Make a note of how many screws you want based on your references, etc.

Step 2.

Cut enough pieces of your styrene rod for the number of screws you want. Cut these at least long enough to pass through your slotting jig with a bit left over for you to hold. The exact length isn't as important as leaving yourself enough to comfortably hold and work with. You'll trim the excess off the model later. Chopping these to length on a piece of glass (which is a very good cutting surface, rough on blades, but prevents the plastic or PE from distorting) is the easy way.

Step 3.

Take each piece and sand one end flat (as viewed from the end, of course). The other end can be left with the wedge shape from cutting (chopping) with an X-acto (don't use your new made saw blade, though). These flat ends will be the ends that get slotted. Putting the rod pieces

through the slotting jig helps when holding them to sand the ends and provides a reference for nice right angles.

Step 4.

Push the flat ends through your slotting jig so that the flat end is flush with the top of the jig (where you made the saw guide). Hold the rod and the jig together from the bottom of the jig so that the rod won't slide up and down as you cut the slot.

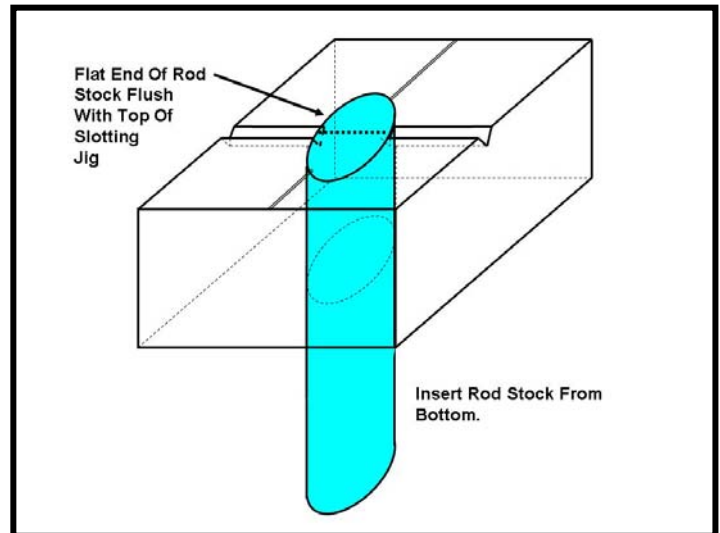

Step 5.

Cut the slot in the end of the rod by making a few light passes with the "ultra-fine" saw blade (using the top of the jig like a miter box). As you make a few screws you'll note that if you don't hold the saw blade as perpendicular as possible to the surface of

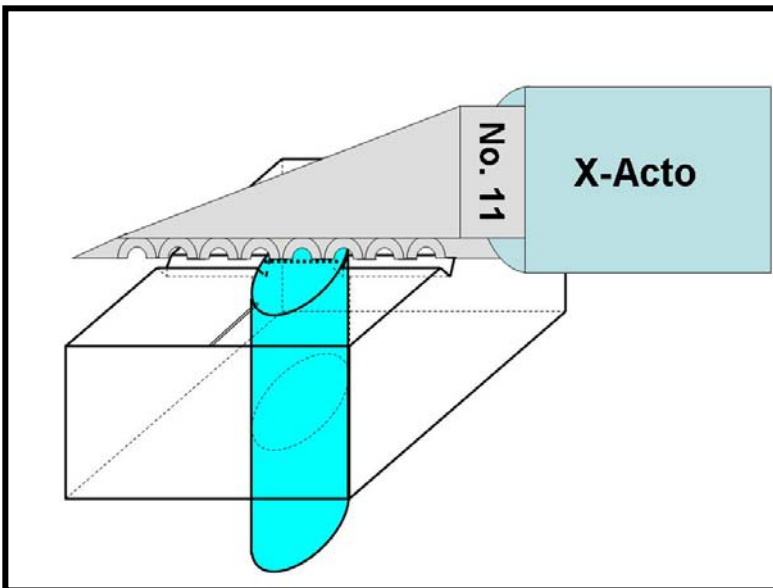

the jig and the end of the rod, the slots "wander" off-center. Compensate by tilting the blade to the opposite side. That should get things back in the groove, so to speak. If not, maybe your jig has worn out. If that's the case, drill another hole in it.

Step 6.

Insert the screws into appropriately sized holes on your model. Do this from the outside to the inside to preserve the detail on the slotted ends. Glue from the inside (if possible). After the glue dries or sets, trim the excess from underneath (or leave if it won't be visible or interfere with other assemblies).

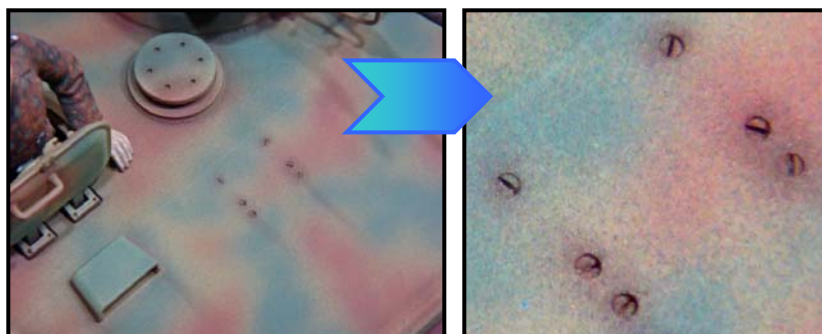

Some Examples of the effects that you can achieve using this technique:

Here's a Tiger I (late) turret. It's the Tamiya kit, and the earlier releases didn't include the screw heads for the hardware that mounts the internal travel lock for the main gun. I added

the screw heads seen here using the homemade jig and saw blade shown earlier.

On the same model a ring of plug-bolt heads around the Nahvertidigungs Waffe (close defense weapon behind the loader's hatch) need to be added.

In this case, the prototype bolt heads are actually inverted cones without screw slots (plug-bolts). The screw heads in the actual weapon are part of the On The Mark Models PE.



A similar problem exists on the Tamiya Panther G (late) kit. The screws are missing from the turret top for both the internal travel lock and around the Nahvertidigungs Waffe. I used the exact same solution. Note again that the screw heads on the weapon are also the kit part. Only the ring of plug-bolts was added.

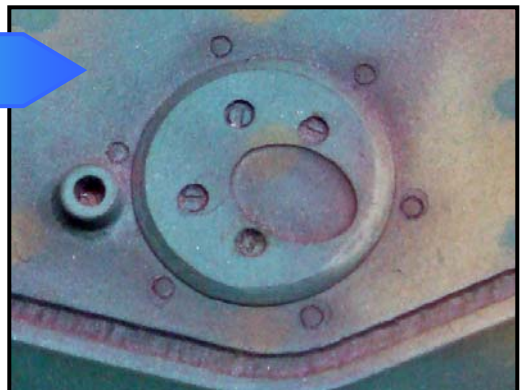

The Panther G also needs a lot of screw head detail added around the driver's and radio operator's hatch area. Again, the slotting jig, homemade saw, and styrene rod provide the solution. Note that here, again, there's a mix of slotted screw heads and conical plug-bolts. References, references, references....

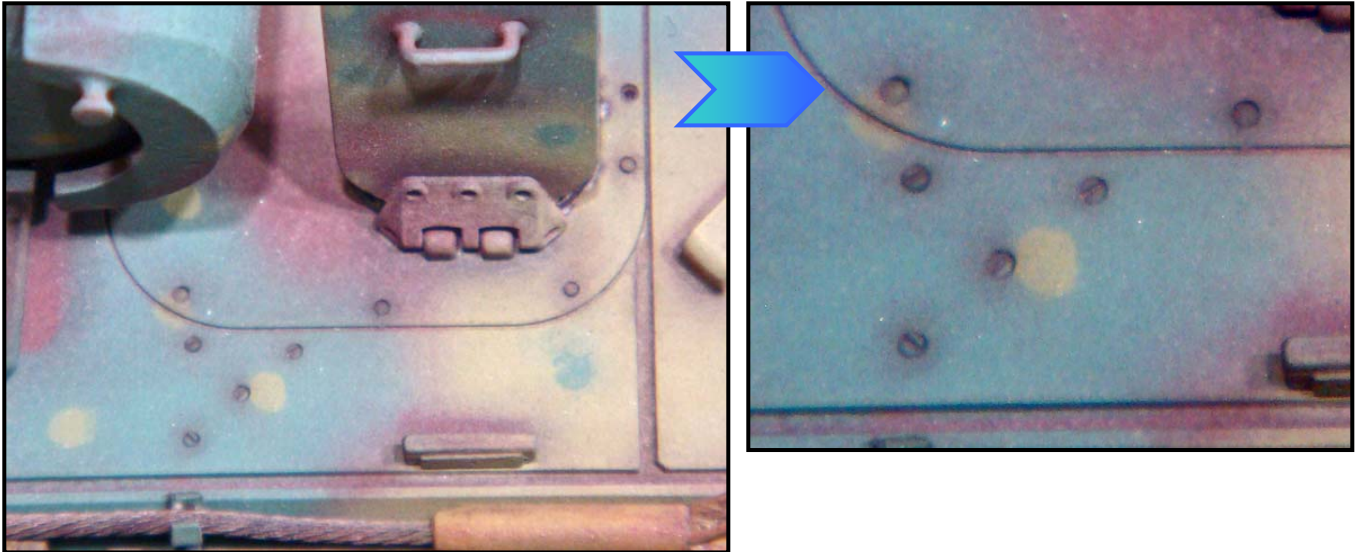

But wait! There's more... The Tamiya Char B1 bis is an all-round fantastic kit. It does, however, have a weak area – Its turret and the commander's cupola both need quite a bit of work to get them accurate. Among the changes needed are, you guessed it, screw heads! Here's my fix, once again using the slotting jig and saw.

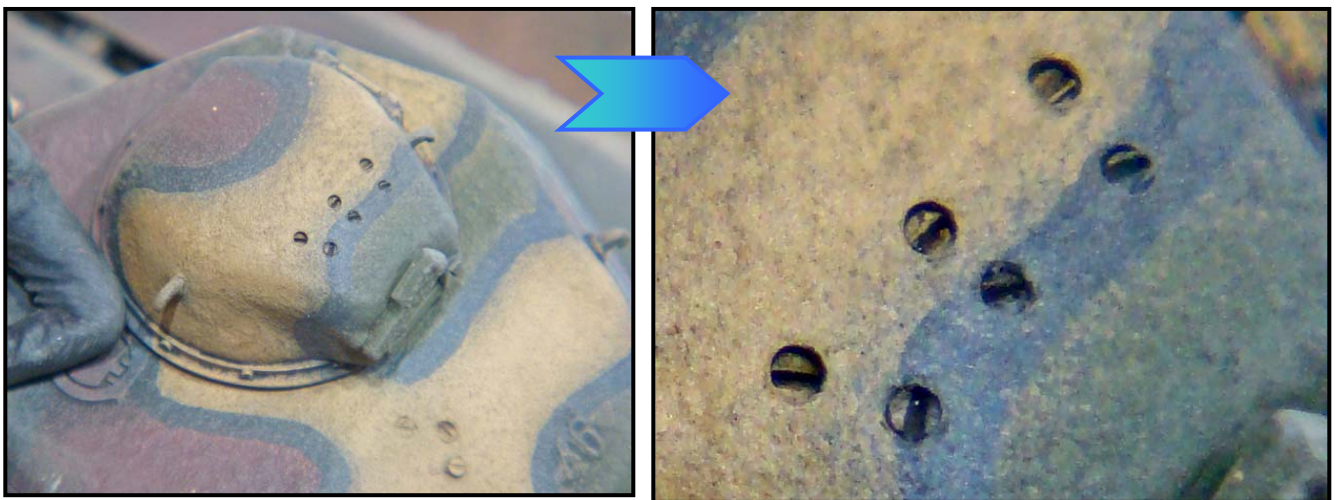

You'll note the three screw heads on the turret roof forward of the cupola. Those are a commercial product: small brass machined screw heads! They are pretty darned nice, but still, they only come in a diameter down to about .6 mm, so for anything smaller, you still have to fab-up the parts yourself. I also used these commercial screw heads across the top of the Char B's driver's vision flap.

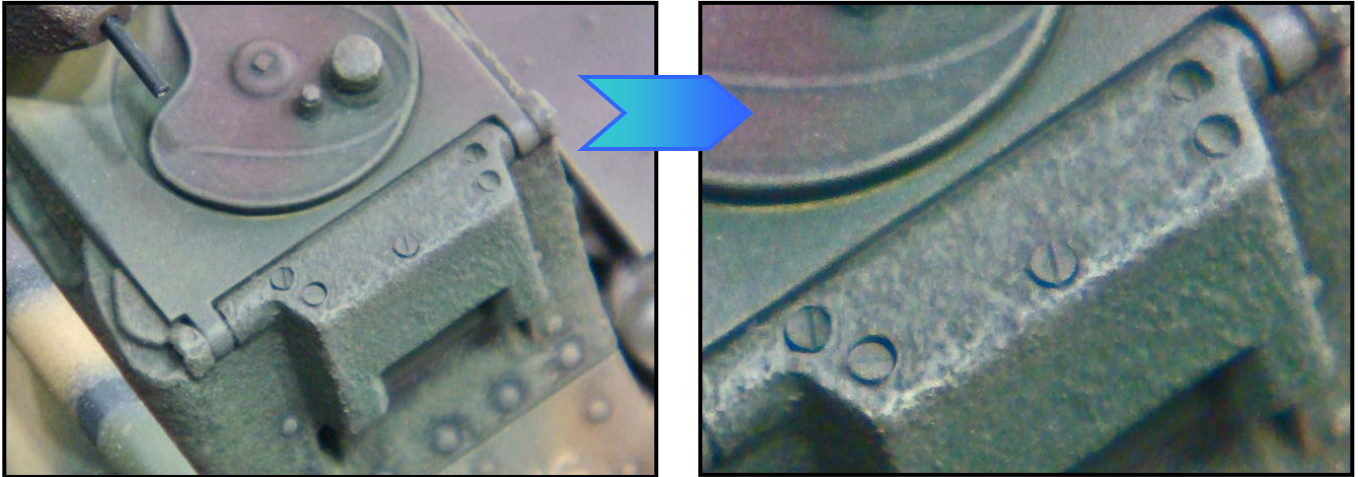

Here's a picture of the commercial screw heads. The ones that I've been using are from Lion Marc and come in packages of about 100 along with a correctly sized drill bit. These are also what I used most recently on the upper mantlet on my Tasca Sherman Firefly, shown below.



*Lion Marc
Model
Designs Brass
Screw Heads
in .6 and .9
mm
Diameters.*

Tasca Sherman Firefly Mantlet Details with Lion Marc Screw Heads

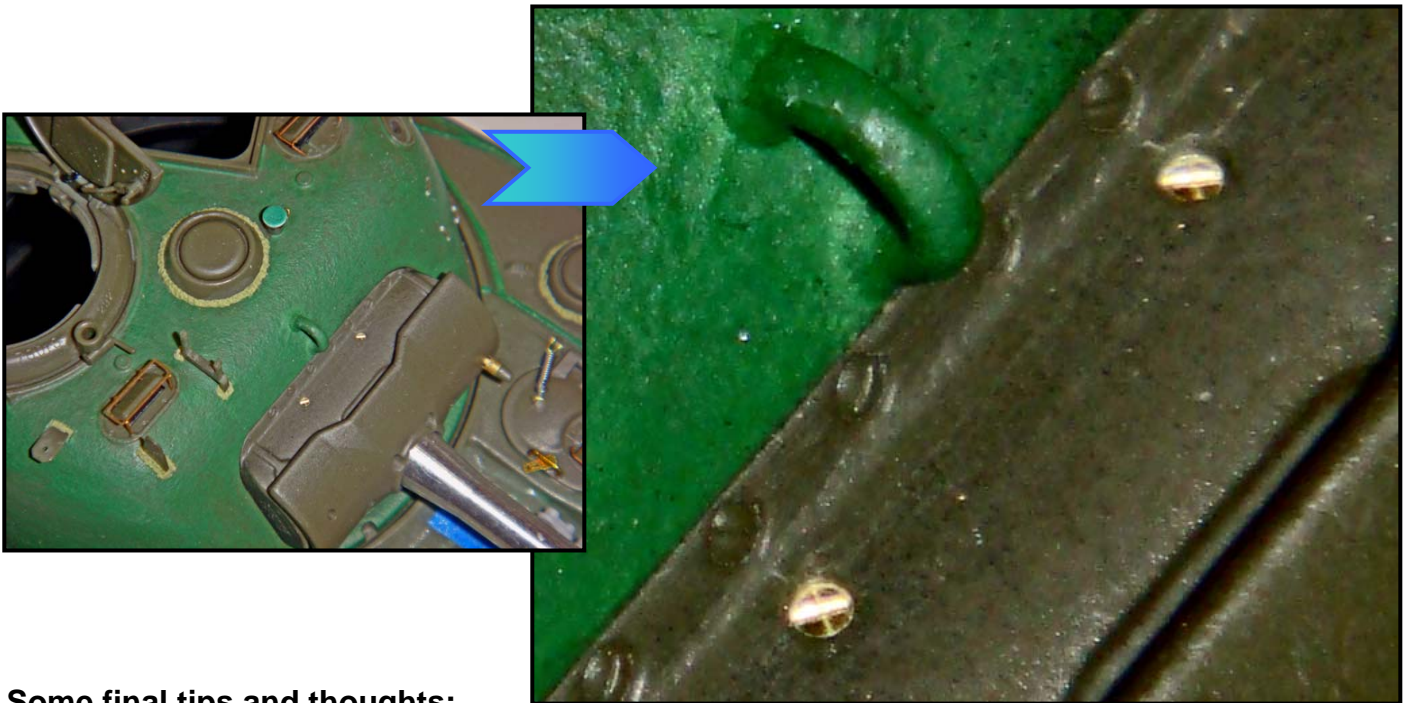

Some final tips and thoughts:

After drilling the screw holes on your model, buff the holes with fine steel wool to slightly relieve the edges so that the screws will not disappear under a coat of paint. Using a set of micro hole-reamers to cleanup the screw holes will also work. I try to leave a slight gap around the edges of the screws so that they remain visible.

The number 11 “ultra-fine” saw blade is useful in other situations besides slotting the styrene rod. It works pretty good for scribing around convex curved surfaces and will actually make good (if shallow) saw cuts, for example on sprue attachment points.

The fine, 0000 steel wool is an all around good item to have on-hand, too. I tend to buff almost all model parts along the mold seams to take out the fine scratches left from the filing and sanding needed to clean up those seams. It also is handy for smoothing out white metal parts (which often seem to have a rough, grainy texture from the talc used by a lot of manufacturers as a mold release agent).

I mentioned using a dial caliper in the “Tools and Supplies” section. If you’re expanding your skill set to do progressively more scratch building, it is one handy thing to have. The one I have is a Mitutoyo brand which will open up to 150 mm. It costs about \$35 some twenty years ago, and can still be had for less than most Tamiya kits today. Besides the obvious measuring, the caliper can be used to scribe lines (for layout and deeper for panels) and the points on the inside measuring arms will accurately layout and “punch” evenly spaced points (like for rivets, bolts and screws). Certainly not an essential piece of kit, but when you need it, nothing else works as well.

Of course, the jig, saw, and styrene rod are an “old school” solution to the problem (sounds like Paul Sr. on “American Chopper”... “I said OLD SCHOOL, Mikey!!!”). In addition to the Lion Marc screw heads, at least one other firm markets similar products: Scale Hardware, www.scalehardware.com . They produce “simulated micro fasteners” in numerous profiles (hex head, rivets, screws, etc) in brass and stainless steel. I haven’t used any of the Scale Hardware products yet, but I’m guessing it’s only a matter of time before I do.

So, in the end, the whole “scratch-built” aspect of the problem can be outsourced to an aftermarket manufacturer. I guess this isn’t really so bad. I’ve been using Grandt Line products for years, so I don’t have any fundamental problems giving up my slotting jig if something better comes along. I am slow, but I’d like to believe that I’m “trainable.”

That’s about it. To give credit where credit is due, the original idea for using slotted styrene rod for screw heads was published by Shep Paine in Modeling Tanks and Military Vehicles, Kalmbach Books, 1982. I got the idea for the “ultra-fine” number 11 saw blade from a reader tip in “Fine Scale Modeler” many (many!) years ago. The slotting jig is my own idea, but I’m sure that I’m not the only person in the world who has thought of it.

And, as if all of the above isn’t enough, though, there is a method that uses a hollow, circular punch (i.e. a piece of metal tubing with a beveled end edge) to emboss the edge of the screw into the surface followed by a chisel edge to emboss the slot inside the circle. I’ve not made screw head detail this way, yet, but, hey, like I said, I’m slow, but “trainable.” You can’t stop learning new tricks. Stop swimming, and you’ll die. Inertia leads to atrophy... and all that other existential stuff.

Mike Roof
AMPS #1632

The Central South Carolina “Wildcats” chapter of AMPS meets every 2nd Wednesday of each month at 6:00 p.m. at the HobbyTown USA, Northpointe Shopping Center, 10120 Two Notch Road, Suite 5, Columbia, SC 29223, (803) 736-0959.

Meetings are open to all persons interested in armor modeling, the history of armored fighting vehicles, and the history of the men and women associated with them.

Please join us!